



General Certificate of Secondary Education
2023

Centre Number

--	--	--	--	--

Candidate Number

--	--	--	--	--

Further Mathematics

Unit 2 (With calculator)

Mechanics



[GFM21]

MV24

WEDNESDAY 21 JUNE, AFTERNOON

Time

1 hour, plus your additional time allowance.

Instructions to Candidates

Write your Centre Number and Candidate Number in the spaces provided at the top of this page.

You must answer the questions in the spaces provided.

Complete in black ink only.

All working **must** be clearly shown in the spaces provided. Marks may be awarded for partially correct solutions.

Where rounding is necessary give answers correct to **2 decimal places** unless stated otherwise.

Take $g = 10 \text{ m/s}^2$ when required.

Answer **all six** questions.

Information for Candidates

The total mark for this paper is 50.

Figures in brackets printed at the end of each question indicate the marks awarded to each question or part question.

You may use a calculator.

The Formula Sheet is on page 3.

Quadratic equations: If $ax^2 + bx + c = 0$ ($a \neq 0$)

$$\text{then } x = \frac{-b \pm \sqrt{b^2 - 4ac}}{2a}$$

Vectors:
 Magnitude of $x\mathbf{i} + y\mathbf{j}$ is given by $\sqrt{x^2 + y^2}$
 Angle between $x\mathbf{i} + y\mathbf{j}$ and \mathbf{i} is given by $\tan^{-1}\left(\frac{y}{x}\right)$

Uniform Acceleration: $v = u + at$ $s = \frac{1}{2}(u + v)t$
 $v^2 = u^2 + 2as$ $s = ut + \frac{1}{2}at^2$

where u is initial velocity t is time
 v is final velocity s is change in displacement
 a is acceleration

Newton's Second Law: $F = ma$

where F is resultant force m is mass
 a is acceleration

[Turn over

- 1 (Throughout this question, \mathbf{i} and \mathbf{j} denote unit vectors parallel to a set of standard x – y axes.)

A package of mass 4 kg is initially at rest at the origin O on a smooth horizontal plane.

The package is acted upon by a force $\mathbf{F} = (7\mathbf{i} - 8\mathbf{j})$ N, causing it to move along the plane.

- (i) Calculate the acceleration of the package in vector form. [2 marks]

Answer _____ m/s²

After 6 seconds the package is at the point P.

(ii) Find the displacement vector **OP**.
[2 marks]

Answer _____ m

The force **F** is the resultant of three forces **a**, **b** and **c**, where

$$\mathbf{a} = (4\mathbf{i} - 7\mathbf{j}) \text{ N} \quad \text{and} \quad \mathbf{b} = (-2\mathbf{i} + 5\mathbf{j}) \text{ N}$$

(iii) Find the force **c** in vector form.
[2 marks]

Answer _____ N

2 A ball is projected upwards from ground level with an initial speed of 30 m/s.

(i) Calculate the time taken for the ball to reach its maximum height. [2 marks]

Answer _____ s

(ii) Calculate the time taken for the ball to fall from its maximum height down to a height of 25 m above the ground.
[4 marks]

Answer _____ s

- 3 A block of mass 5 kg is pulled in a straight line along a **rough**, horizontal plane by a force of 30 N, acting on the block at an angle of 37° to the horizontal, as shown in the diagram below.

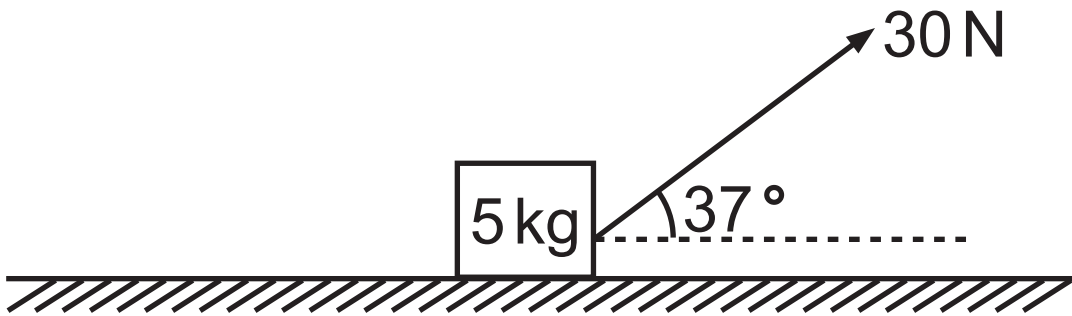

- (i) Calculate the normal reaction between the block and the plane. [2 marks]

Answer _____ N

The block is moving with **constant** velocity.

(ii) Calculate the force due to friction.
[2 marks]

Answer _____ N

The force of 30 N is removed and replaced by a force of 45 N, acting at an angle of 42° to the horizontal, as shown in the diagram below.

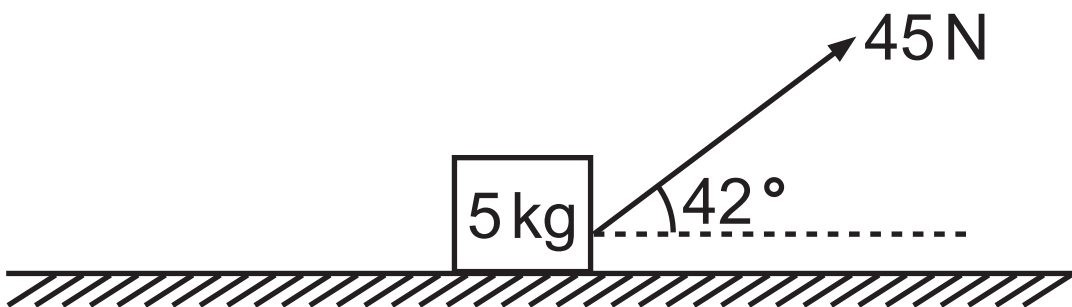

The value of the frictional force is now 15 N.

The block moves with constant acceleration.

(iii) Calculate the acceleration of the block.
[3 marks]

Answer _____ m/s²

- 4 Two blocks, P and Q, of masses M kg and 9 kg respectively, are connected by a light, inextensible string that passes over a smooth pulley.

Block P is held at rest on a **rough**, horizontal table, and block Q hangs vertically above the ground, as shown in the diagram below.

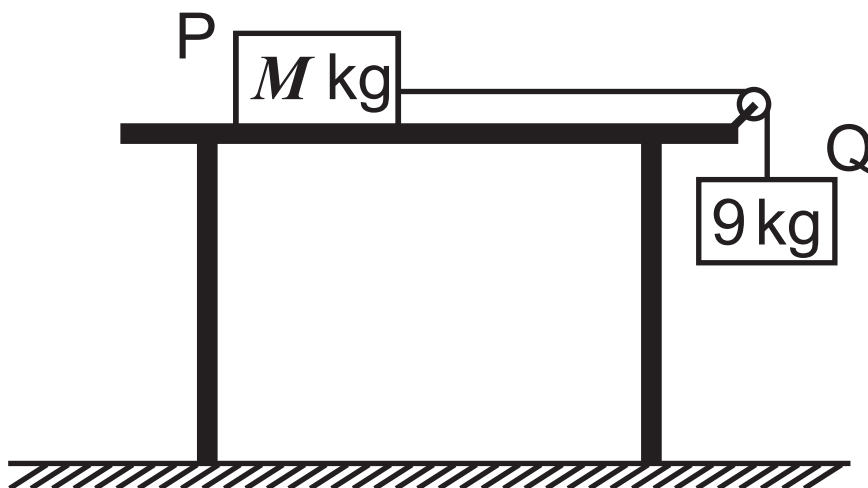

The blocks are released from rest.
The force due to friction is 51.6 N.

- (i) Mark, on the diagram above, all the forces acting on the blocks. [2 marks]

After 0.75 seconds, Q has moved down 0.675 m and P hasn't reached the pulley.

(ii) Calculate the acceleration of the blocks.
[2 marks]

Answer _____ m/s²

(iii) Calculate the tension in the string.
[3 marks]

Answer _____ N

(iv) Calculate the value of M . [3 marks]

Answer _____

Blank Page

(Questions continue overleaf)

- 5 A uniform rod AB rests horizontally on a pivot.

The pivot touches the rod at the point C.

The rod is of length 6 m and mass 3.5 kg, and the distance AC is x m.

A mass of 4.5 kg is attached to the end A and a mass of 2 kg is attached to the end B, as shown in the diagram below.



The rod remains horizontal and in equilibrium.

- (i) Mark, on the diagram above, all the forces acting on the rod. [2 marks]

(ii) Calculate the reaction at the pivot at C.
[1 mark]

Answer _____ N

(iii) Calculate the value of x . [4 marks]

Answer _____

- 6 A car is travelling at a constant velocity of 16 m/s .

It passes a stationary motorbike, and 10 seconds later the rider of the motorbike gives chase.

The motorbike accelerates uniformly for 15 seconds until it reaches a velocity of 24 m/s . It continues at this velocity until it catches up with the car.

- (i) On the axes below, sketch the velocity–time graph for the motorbike.
[2 marks]

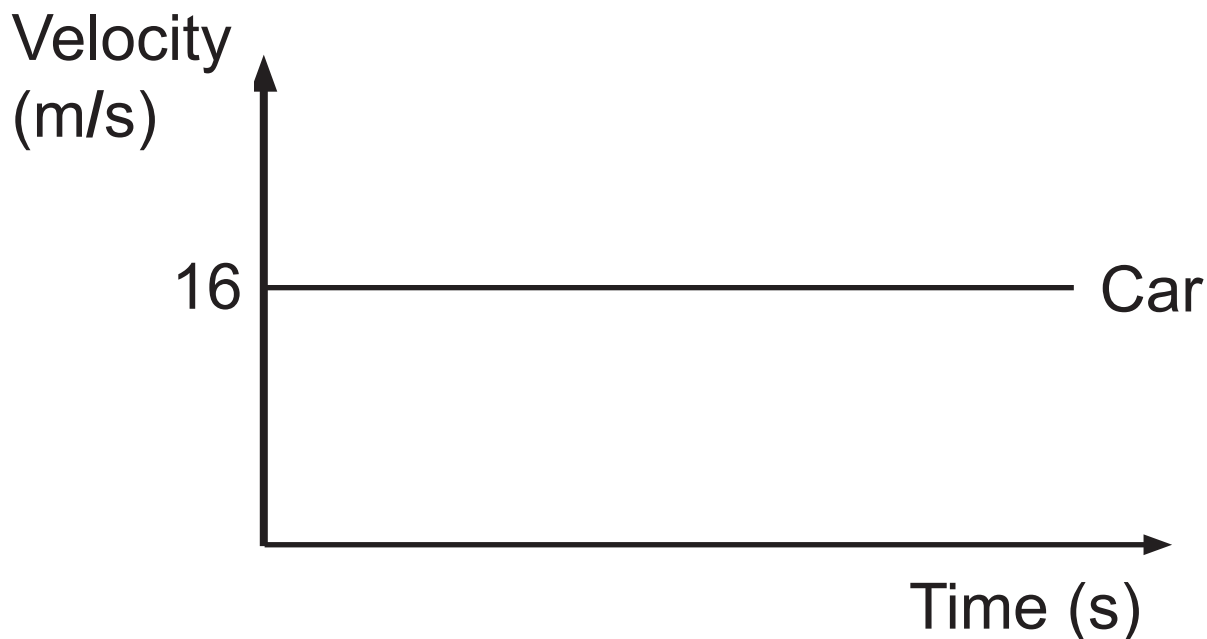

Hence, or otherwise, after the motorbike starts moving, calculate

(ii) the time taken for the motorbike to catch up with the car, [5 marks]

Answer _____ s

(iii) the distance which the motorbike has travelled in this time. [2 marks]

Answer _____ m

The moment the motorbike reaches the car, the motorbike decelerates at 1.6 m/s^2 until it comes to rest.

The car continues travelling at 16 m/s .

(iv) After the motorbike comes to rest, which vehicle is further ahead, and by how far?
[5 marks]

Answer _____ is further ahead
by _____ m

**This is the end of the
question paper**

For Examiner's use only	
Question Number	Marks
1	
2	
3	
4	
5	
6	

Total Marks	
--------------------	--

Examiner Number

Permission to reproduce all copyright material has been applied for.
 In some cases, efforts to contact copyright holders may have been unsuccessful and CCEA will be happy to rectify any omissions of acknowledgement in future if notified.